



<b>Q</b> SERIES	Quieter pump Improved mounting Enhanced operation Increased functionality
--------------------	--

# Weather Responsive Solar Powered Watering Systems

<b>C18   Q SERIES</b>				
18x	18x	36x	7x	18x

<b>C36   Q SERIES</b>				
36x	36x	72x	14x	36x

**CZ** **DE** **EN** **ES** **FR** **NL** **SE** [irrigatia.com/q](https://irrigatia.com/q)

Instructions may have been updated / improved, latest version can be found here:



**Designed in Britain**

MORE SUN = MORE WATER

SOLAR POWERED

WATERS EVERY 3 HRS

2 PUMP PROVISION

USE WITH A RAIN BARREL

## Introduction

Thank you for purchasing one of our systems!

Over the last decade Irrigatia has constantly been improving and developing its watering systems, with the latest version being the Q Series!

- It's quieter
- It's more efficient
- It's easier to mount / position
- It can be upgraded with a second pump, liquid feed or second network
- Increased functionality, now 9 levels
- New improved dripper

Whilst our systems are still:

- Weather responsive, more sun / more water, less sun / less water
- Repairable, we believe in fixing, not binning
- Patent protected, still unique!

### SAFETY NOTE

- Please be aware that this product contains small parts / components and batteries, that could be a choking hazard to children and animals, so care should be taken during setup and installation.
- Due to the nature of the product, there is the potential of trip hazards, so care should be taken with the installation of the watering network tubing and water level sensor cables.
- The controller is designed to be weatherproof and to deal with all types of weather conditions, but is not designed to be submerged in water.
- At end of life, the product and batteries should be disposed of according to local disposal / recycling legislation and requirements.

### Repair and Recycle

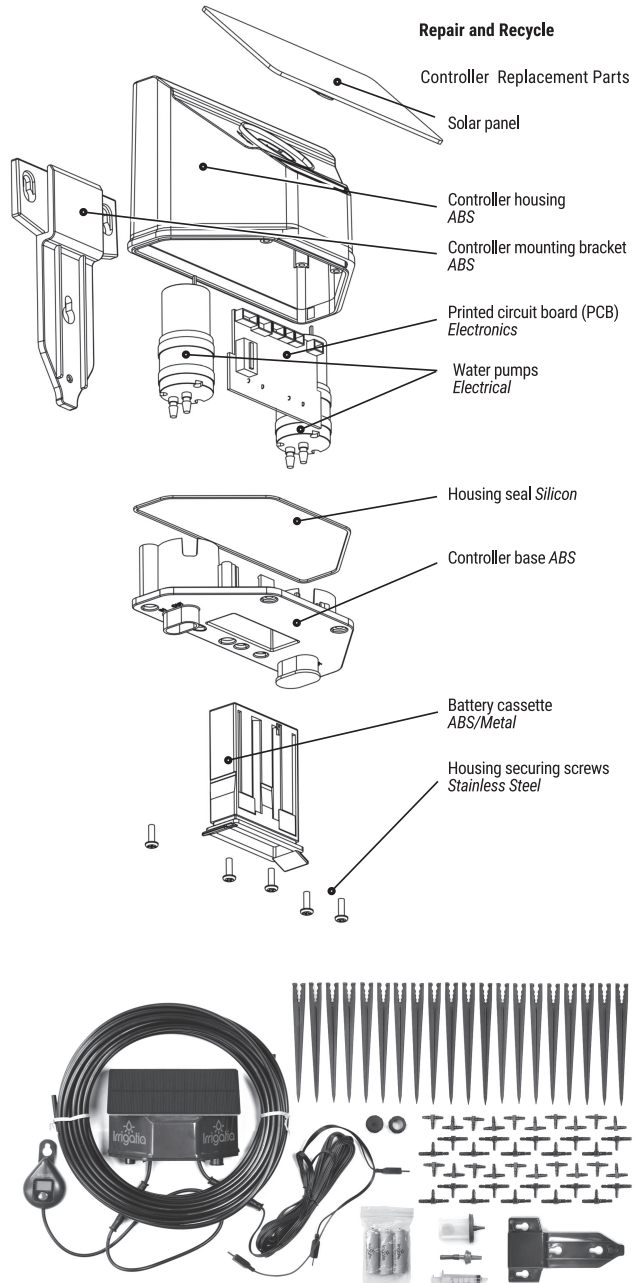

## What Comes in The Box and What it Does

---

### Controller

It controls the system and houses the batteries and pump, whilst also having the solar panel mounted on it.

The batteries inside are charged by sunshine captured by the solar panel.

The batteries power the pump, which draws water from the source, to water your plants.

The pump starts every 3 hours during daylight and stops when the batteries fall to 3V.

The system is controlled by the Hand Control Module which is connected to the controller.

---

### Batteries

Supplied 3 x AA rechargeable, 1.2V NiMH batteries between 1200 and 1800mAh

---

### Hand Control Module

Houses the LCD screen, the set control button and two LEDs, one red, one green.

It is attached to the controller by a 50cm cable, an optional 3m extension cable is available, IRR-HCM-QEXT.

The module can be clipped onto the controller mounting bracket.

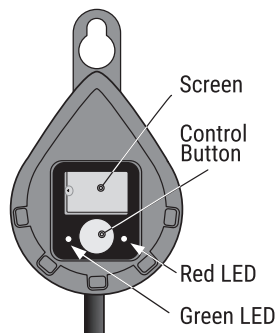

---

### LCD Screen

Displays the time to next watering (3-1 hours) and the set point (1-9) and error codes.

Default display is the duration to next watering (3h/2h/1h), with a press of the button, it will show the set point, with a further press of the button, the set point can then be changed.

If there are any alert / error codes it will display the highest priority first, pressing the button will reveal other codes in order of priority, then finally the set point.

At night the screen will illuminate for 5 seconds if the button is pressed.

**Green LED** Flashes the current set point 1 to 9, if there are no alerts

**Red LED** Flashes every 5 seconds for low priority codes (low water, high pump power, feed run out) Double flashes every 5 seconds for urgent codes (no water, low pump power – indication of no pumping)

---

### Solar Panel

Can be repositioned to allow for easier mounting of controller, to enable South facing mounting.

Can be mounted inside windows, but might reduce

pumping times marginally, ideally do not have shadows cast over the panel.

---

### Inlet Filter

Located within the water source, prevents debris from entering the system and blocking the pump and drippers.

Is located at the end of the inlet feed tube.

---

### Water Level Sensor

Checks that there is water to pump / feed into the system, length of cable is 5m.

Via the controller, it lets the user know when the water level is getting low, and then eventually when it has run out.

Once run out, the system will turn off automatically. You are alerted by audible beeps and an error code

on the Hand Control Module.

If required the sensor can be turned off.

Another option is to leave the sensor on and turn the beeper off.

To remove the water sensor unscrew the connector on the wire close to the controller, an end cap is supplied.

---

### Anti-Siphon Device

Prevents further dripping once the pump has stopped.

It is a one-way valve which works by opening to allow air into the tube to break the siphon when the pump stops.

The anti-siphon device is needed if the first dripper is lower than the water source.

It should be fitted to the delivery tube between the pump and first dripper and must be higher than the water source.

---

### Stakes

Used to hold drippers and tube in place.

---

### Tube

3.5mm internal diameter tube used to draw water from the barrel and deliver it to your plants.

15m and 30m extension kits are available if extra tube is needed.

---

### Drippers

Used to feed / drip water directly to the plant, simply push into the end of the tube.

Is also acts as the connector for Seep Hose if this is chosen to be used.

When water is no longer required to be fed, it can be re-used as a stopper.

Should a dripper ever become clogged, just remove and wash and re-install.

Wash with kettle de-scaler if mains water has been used.

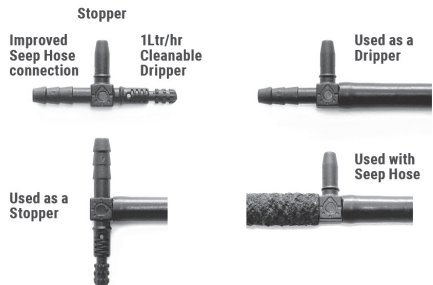

**Tees**

Tees are used to connect the tube to produce the specific watering layout you require.

The tube needs to be pushed completely on to avoid leakage.

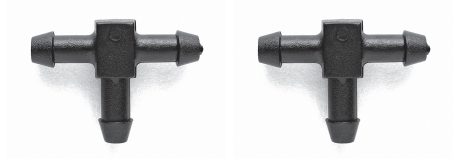

**Syringe**

With a short piece of tube attached, this can be used for the reverse flushing of drippers or the forward

flushing of the pump, should they ever become blocked.

**Installing the Product**

There are four stages to installing the product.

Stage 1 – Internal Configuration

Stage 3 – Addition of Watering Network

Stage 2 – Initial Set Up and Initialisation

Stage 4 – System Operation

**Stage 1 – Internal Configuration**

Inside the controller unit, there are switches which allow the system to have features set.

Now is the time to consider these, before the controller is mounted.

The picture shows the defaults as supplied, there is nothing that needs changing to begin with.

Only change if you want to undertake any of the following:

Switch 1 – “Night” watering, switch to OFF

Switch 2 – System to be managed by an external control source, switch to ON

Switch 3 – Upgrade with second pump and switch to ON

Switch 4 – Use second pump for liquid feed, switch to ON, OFF is for watering a second network

Switch 5 – If you do not want a warning beeper, switch to OFF

Switch 6 – If you do not want to use the water level sensor, switch to OFF

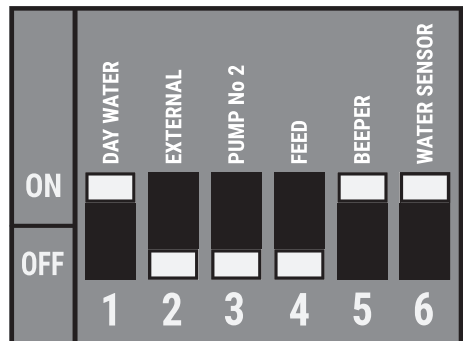

## Stage 2 – Initial Set Up and Initialisation

These instructions detail how the controller needs to be installed, along with connection to the water source.

The system runs on three rechargeable batteries, with an operating voltage of 3.6V

The batteries provided at the start have a voltage of 4.1V and need to be discharged partially to begin with.

Once this discharge / initialisation stage is completed, the system will be ready to have the watering network added to it.

NOTE – Should in the future any new or externally charged batteries be used in the system, then the discharge process will need to be repeated.

### 1-Location of Controller

The distance from the water source is governed by the length of the water level sensor cable, 5m.

As standard, can be a maximum of 3.5m horizontally from the water source and 2m from the bottom of the source.

If the optional 3m extension is fitted, IRR-WLS-QEXT, can be a maximum of 6.5m horizontally from the water source and 2m from the bottom of the source.

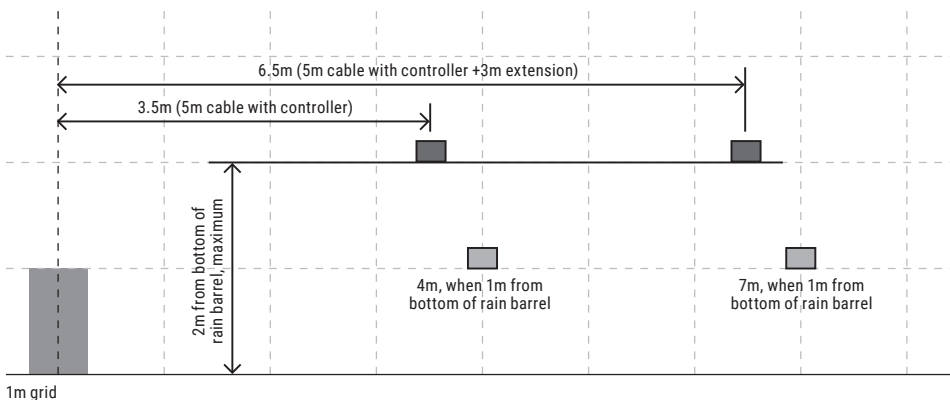

### 2-Mounting of Controller

The controller needs to be mounted in a South facing position, and at least 30 cm higher than the water source.

It should not be laid down.

The controller has both front and rear mounting positions for the bracket.

The controller can be mounted to a wall, or a post using the bracket or attached directly onto glass using the front mounting position using the adhesion pad supplied with the kit.

When mounted inside windows, pumping times might be reduced marginally, ideally do not have shadows cast over the panel.

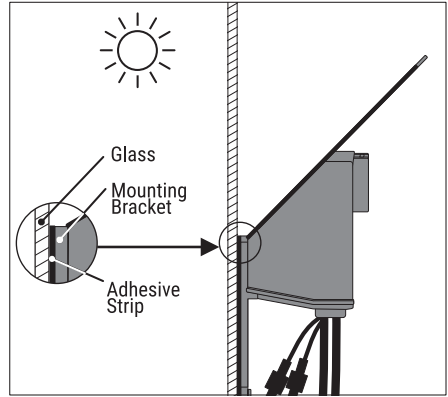
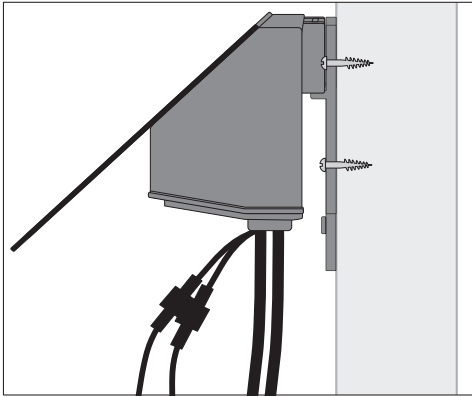

The solar panel can be easily rotated to suit the mounting position / orientation required.

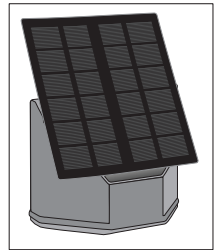
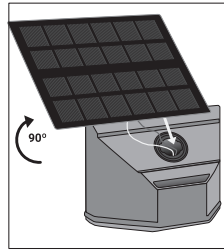
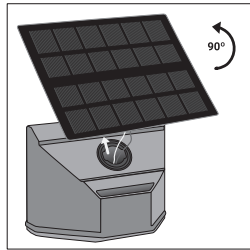
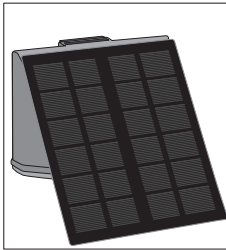

- 1) Rotate the solar panel 90° anticlockwise and gently lift 2cm.
- 2) Rotate 180° anticlockwise and insert back into the controller housing.
- 3) Rotate the solar panel 90° clockwise to lock it in the housing.

### 3-Batteries

Remove the battery cassette from the base of the controller.

Insert the three batteries, paying attention to orientation, into the cassette.

Push the cassette back into the controller.

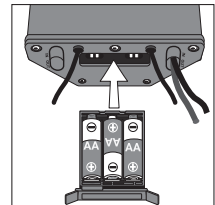

### 4-Water Level Sensor & Filter & Source Feed

This section deals with the water source and connecting it to the controller, with the water level sensor.

Ensure the water source is light proof, this will prevent algae being produced.

Drill a 5.5 mm hole near the top of the water source, or use any pre-made hole, above the waterline but low enough to use the lid normally.

Thread one end of tube through the inlet hole and attach the filter to the end.

If using the water sensor, a hole of at least 10 mm is required to thread through.

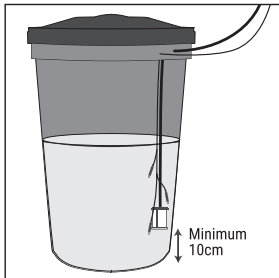
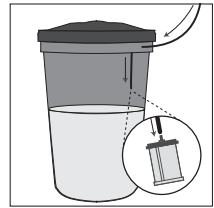
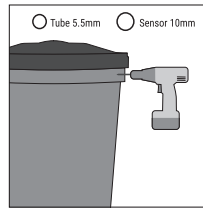

Attach water level sensor and tube/filter together using the cable ties provided so that the middle sensor is 2cm above the filter and the bottom sensor is hanging below the filter.

The top sensor can be adjusted to give the warning level needed.

The tube should now be adjusted so that the filter hangs at least 10cm above the barrel bottom.

Now the tube can be cut to length (leave a little spare) and connected to the pump inlet (marked in) on the left side of the controller.

Connect the water level sensor to the controller.

## 5-Water Out

Connect a suitable length of tube from the outlet port on the pump in the controller, and feed back into the water source.

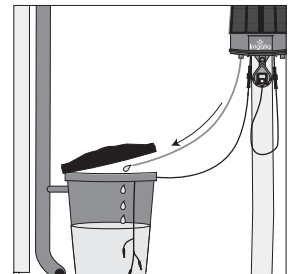
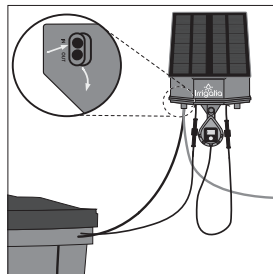

## 6-Operating the Controller

On the Hand Control Module, press the button for 3 seconds, this will turn the system on.

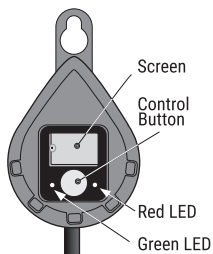

## 7-Start initialisation

Press the button a multiple of times until 1d appears on the screen, if you go past, just cycle through the numbers again.

Set point 1 charges the batteries the least, whereas level 9, charges them the most, by using level 1, it will drain the batteries more quickly.

The system will now start pumping and feeding water back to the water source, check that this is happening.

Batteries will gradually be depleted down to their operational voltage.

This process should take approx 2.5 hours



## Stage 3 – Addition of Watering Network

### 1-Initialisation complete

Initialisation is complete, when upon returning back to the controller, you see just the green led flashing and either 3h/2h/1h being displayed.

The system is now ready to have a watering network added to it.

For now, press the button on the hand control module, for 3 seconds, and turn the system OFF.

### 2-Addition of watering network

Remove the water out tube which is feeding back into the water source – this will now be the supply feed for your network.

Consider your layout / requirements, the following diagrams and suggestions can help you.

#### SMALL POTS AND TRAYS



#### LARGE BED WATERING

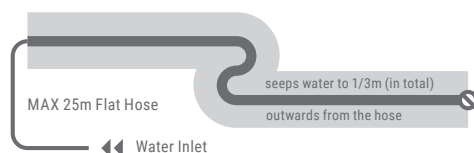

#### WATERING AT DIFFERENT HEIGHTS

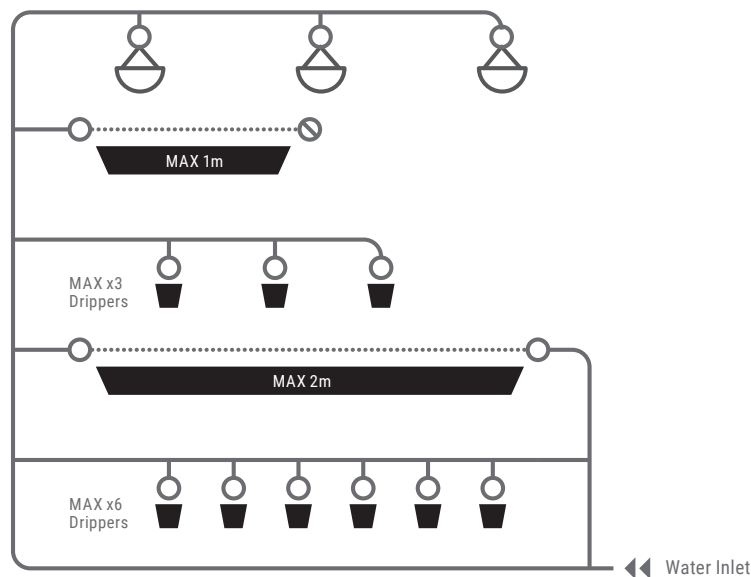

**FLOWER & VEGETABLE BED WATERING**

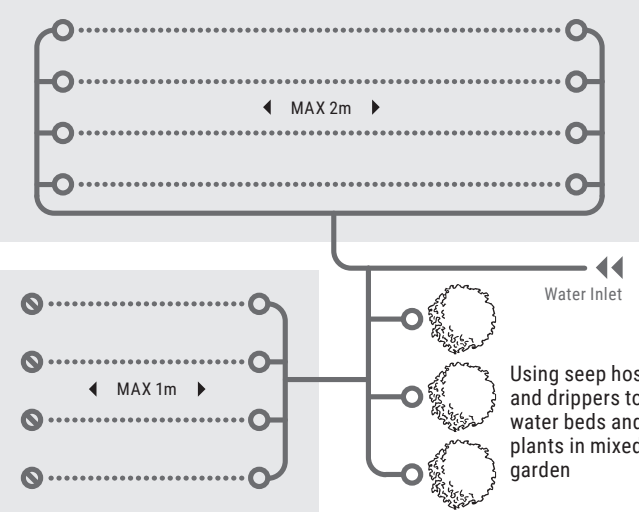

**KIT REQUIRED:**  
**C18Q:** 1 set up (as shown) + 12m Seep Hose  
**C36Q:** 2 set ups (as shown + 24m Seep Hose)

**GREENHOUSE WATERING**

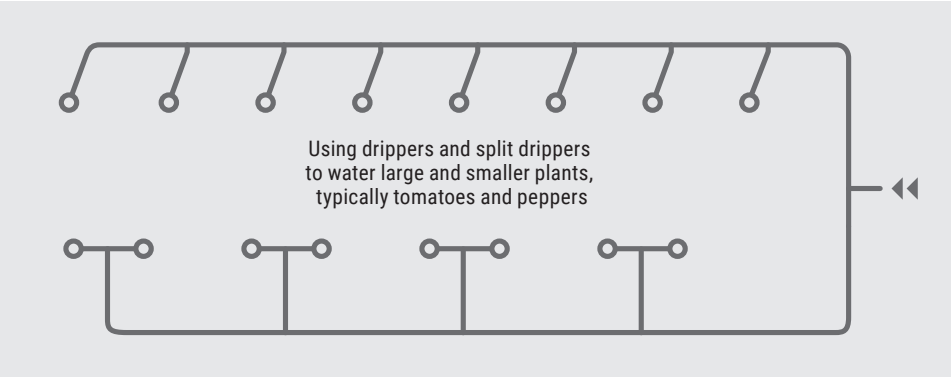

**KEY**

- Tube
- Flat Hose
- Plant Tray
- Large Plant
- Dripper
- Trough
- Plant Pots
- Hanging Basket
- Stopper
- Seep Hose

### Anti-Siphon Device

Install the anti-siphon device if the first dripper is lower than the water source.

It should be fitted to the water out tube between the pump and first dripper and must be higher than the water source.

Its purpose is to prevent further dripping once the pump has stopped.

It is a one-way valve which works by opening to allow air into the tube to break the siphon when the pump stops.

Install if in any doubt, since it will not do any harm to how the overall system works.

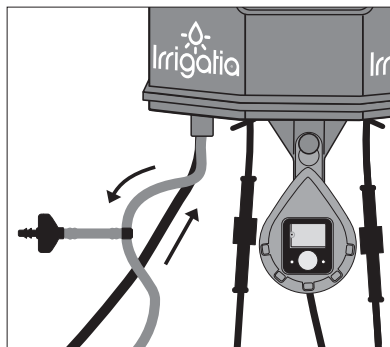

### Drippers

Ensure the dripper is connected correctly, they simply push into the tube.

Plants are supplied with a controlled amount of water by the drippers.

They should be positioned in pots or close to the plants to be watered.

The system / network will not work unless there is a dripper, or stopper, in every tube end.

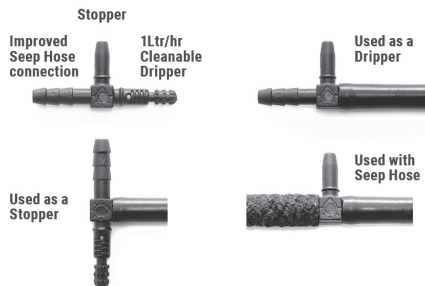

- The furthest and highest distance, will be governed by each individual end user set up
- Variation in height between drippers will also affect flow
  - 18 drippers installed, maximum height between lowest and highest dripper is 2m

- 36 drippers installed, all need to be approximately level
- If an application is requiring both 'high' and 'low' watering, then it is best to install a second pump
  - Pump 1 – waters 'low'
  - Pump 2 – waters 'high'

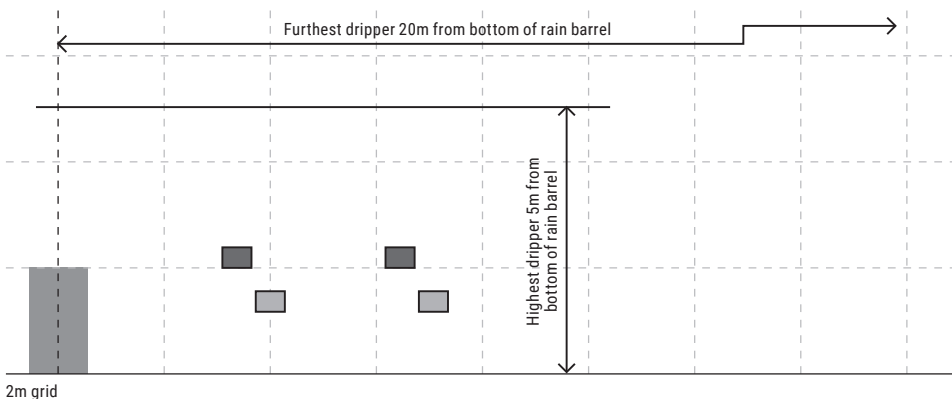

2m grid

---

Drippers cannot be installed more than 5m above the bottom of the water source.

With 18 drippers installed, there should be no more than 2m difference in height between the highest and lowest

With 36 drippers installed, they should all be approximately level.

If a dripper is not currently needed it can be removed and the stopper inserted.

---

### Seep Hose

This porous rubber hose emits water along its length, when the system is running.

It is connected to the network using the dripper, as per pictures.

Product code IRR-SH12, comes in a 12m length and is cut to suit.

Seep Hose will water better and last longer if protected from the sun with a layer of mulch.

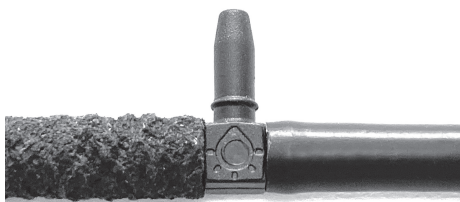

---

### Flat Irrigation Hose

Ideal for rows of vegetables, or winding through borders and raised beds.

Connects into the network tube directly.

Product code IRR-SOAK, comes in a 25m length and is cut to suit, (parts for 10 lengths provided).

Soil water will be retained longer if covered by a layer of mulch.

## Stage 4 – System Operation

---

With the batteries initialised and the watering network added, the system can now be operated.

---

### 1-Operating the System

Pressing the button on the Hand Control Module for 3 seconds will turn the system on, or off.

The LCD display on the Hand Control Module will indicate the duration, in hours, until next watering occurs, (3h/2h/1h) and with a press, will show the set level, (1d-9d).

If there are any alert / error codes it will display the highest priority first, pressing the button will reveal other codes in order of priority, then finally the set point.

At night the screen will illuminate for 5 seconds if the button is pressed.

Green LED Flashes the current set point 1 to 9, if there are no alerts

Red LED Flashes every 5 seconds for low priority codes (low water, high pump power, feed run out)

Double flashes every 5 seconds for urgent codes (no water, low pump power – indication of no pumping)

Once the current set point is being displayed it can be reset by using brief presses of the button to scroll to a new setting. This controls the charging duration of the batteries.

Setting level 1, the solar panel is switched on for 30 seconds in a five minute cycle which is increased by 50% for each setting, up to level 9, when the solar panel charges the batteries continuously.

---

### 2-Re-Start the System

Press the button on the Hand Control Module for 3 seconds and turn the system back on.

Set the Hand Control Module to level 6 as a starting point.

Check for leaks and that everything is working ok.

Should any dripper not be dripping, simply remove, let water flow and re-insert.

If Flat Hose, or Seep Hose is being used, please wait 2-3 days, for all the air to be pushed out of the

network. The controller will start the pump every 3 hours during the day.

The pump will run until the batteries drop to 3V.

The duration of watering is determined by the combination of light intensity reaching the solar panel (the weather) and the 1-9 level setting (the plants needs).

The watering is not a set duration and will vary between each cycle.

---

### 3-On-Going Setting Level

After a few days review the setting level and adjust up or down, depending on your specific results / requirements.

Do note that as plants grow, or their demands change, then the setting level should be changed also.

### LCD Screen and Display Codes

Displays the time to next watering (3-1 hours) and the set point (1-9) and error codes.

Default display is the duration to next watering

(3h/2h/1h), with a press of the button, it will show the set point, with a further press of the button, the set point can then be changed.

Code	Definition	Pump	Action Required
1d-9d	Set point Day Watering	Can run	None
1n-9n	Set point Night Watering	Can run	None
10	Night mode (when controller in day watering)	Does not run	None
11	Day mode (when controller in night watering)	Does not run	None
20	No water (Middle water sensor is exposed)	Does not run	Top up water in water source
21	Low water (Top water sensor is exposed)	Can run	Top up water in water source
30	Pump off due to external control (Controlled by switch 2 inside)	Does not run	None
81	Low power pump 1	Can run	Check pump 1. Check flow rate through a short tube on the pump outlet, should be at least 300ml/minute. If not, clean pump.
82	Low power pump 2, when feed off	Can run	Check pump 2. Check flow rate through a short tube on the pump outlet, should be at least 300ml/minute. If not, clean pump.
83	High power pump 1	Can run	Replace pump 1 there is a motor fault
84	High power pump 2	Can run	Replace pump 2 there is a motor fault
85	Low power pump 2, when feed on	Can run	If loud pumping noise, then pump may be dry, check feed level. Check pump is pumping for 3 seconds every minute. Pump may need cleaning.
89	Pump 2 switched to feed Pump 1 low power	Does not run	Check pump 1. Check flow rate through a short tube on the pump outlet, should be at least 300ml/minute. If not, clean pump. NOTE – Pump 2 will not run to avoid over feeding

## Night Watering

---

The system can water at “night”, technically just after “dusk”.

Via the solar panel, because it essentially stops charging due to the sun going down, it knows when “dusk” occurs each day.

To utilise this watering feature, you will need to set Switch 1, to OFF, inside the controller on the printed circuit board before installation.

Once the system has detected “dusk” it will water 30 minutes afterwards.

It will water for a single long duration of time – this is ideal for networks that are utilising hose-based products such as Flat Hose and Seep Hose.

As per day use, the watering set point level is adjusted by multiple presses of the button on the Hand Control Module, so 1n through to 9n, we suggest that you start at 6n and adjust from there.

With “Night Watering” activated,

- During the day, you will see code 11 on the Hand Control Module, with a press of the button, you will then see the set level, such as 6n.
- At night, if you press the button on the Hand Control Module, the lcd panel will light up, and you will then see code 10, with a further press, you will see the set level, such as 6n

## Upgrade the Controller With Two Pumps

---

The product has the option to have an additional pump installed within the controller.

This additional pump can be used for the pumping of liquid feed into the main water supply, OR, for the watering of an additional network.

When feeding plants / pots with a liquid feed, the two pumps don’t actually run at the same time, they alternate, 57 seconds watering (primary pump 1), 3 seconds feed (second pump 2).

When watering a second network with the second pump, the network is configured in a similar fashion to the primary one, using drippers or hose based products.

The upgrade kit can be sourced from our web shop, IRR-UPCQ

## Upgrade the Solar Panel, C18Q

---

If you have purchased a C18Q model, and after a period of use, you need greater capability, the solar panel can be upgraded to that of the C36Q model.

Visit our web shop and purchase the C36Q solar panel, IRR-PANEL-C36Q

More information can be found at: [irrigatia.com/how-it-works](http://irrigatia.com/how-it-works)



## C18 | Q SERIES



18x



18x



36x



7x



18x

## C36 | Q SERIES



36x



36x



72x



14x



36x

For further information on this or any of the other products in our range, please visit:

[irrigatia.com](http://irrigatia.com)

### Irrigatia Limited

Norwoods, Long Drax, Selby, North Yorkshire, YO8 8TA  
United Kingdom Telephone: +44 (0) 333 301 0415

### Irrigatia B.V.

Neonweg 12 E, 3812 RH, Amersfoort, Netherlands

